

TRANSPARENCY IN THE SMART GRID

SOLUTIONS WITH AN OPEN &
SCALABLE MEASUREMENT
SYSTEM

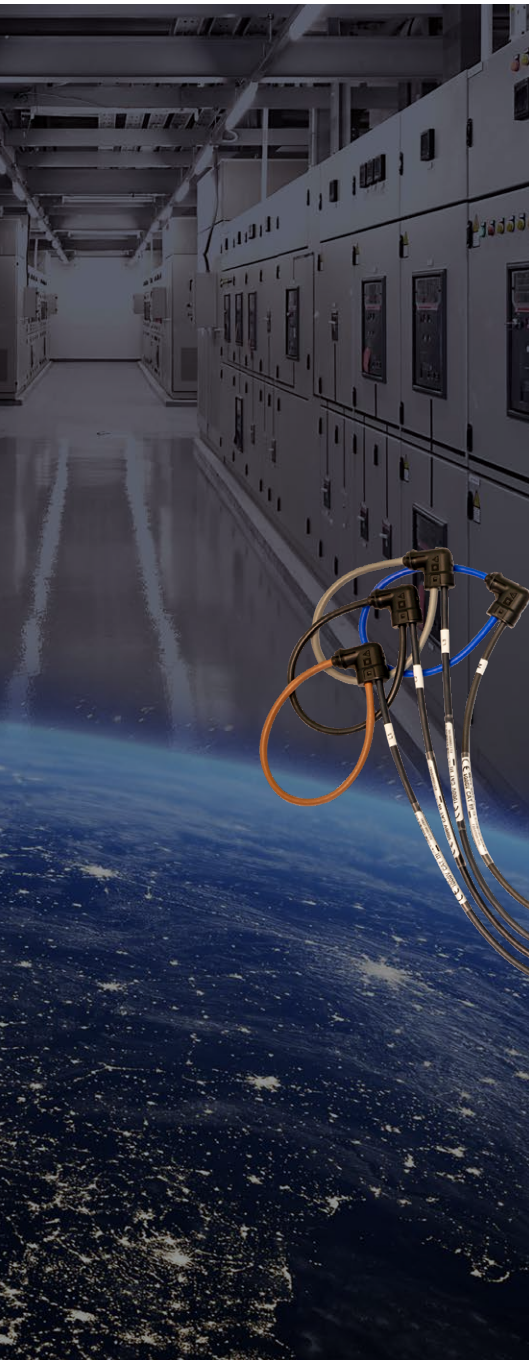

LINAX® PQ5000CL

Load flows ■ Compliance EN 50160 ■ Events



Power quality assessment with scalable load flow information

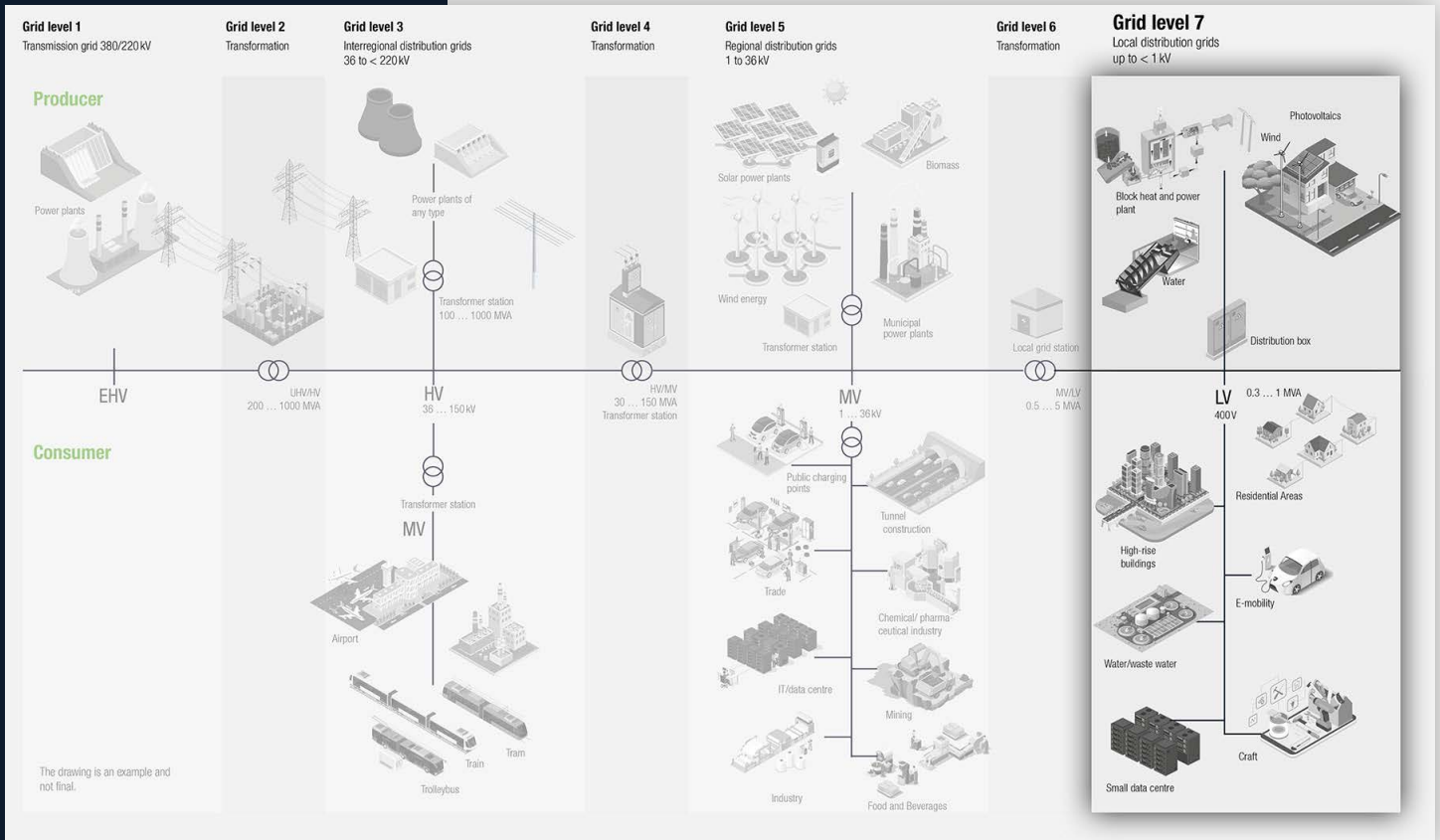

Due to the increasing changes in electrical networks, load flow information is becoming more and more important, for distribution network operators in particular also in combination with power quality data. For many distribution network operators, corresponding information at network level 7 (low voltage) is either not available at all or only insufficient. Without a proper smart grid solution, this would be equivalent to «flying blind».

Since many consumers are increasingly also producers, i.e. so-called prosumers, new technical as well as commercial solutions are increasingly in demand. Intelligent metering systems (smart meters) are of no help here, as they are only suitable for grid management to a limited extent due to data protection rules and also insufficient performance, among other things.



WHAT DOES SMART GRID ACTUALLY MEAN

The challenge

One of the great challenges is that the formerly centralized electrical energy world has developed into a highly dynamic as well as very complex decentralized system. In this context, it must be possible to systemically process new but relevant information in a targeted handling of data.

players and society. The use and operation of the system can thus be optimized and made more efficient, costs and environmental impact can be minimized, and the quality and security of supply can be guaranteed to a sufficiently high degree.

Source: Swiss Federal Office of Energy SFOE

(e.g., scalability, real-time, connection to existing control systems, integration into new platform solutions, connectivity, distinct technical consulting needs, cyber security, additional costs, etc.). Thus, the traditional IEC groupings of electrical instrumentation will possibly change and overlap even more.

Definition Smart Grid

A smart grid is an electrical system that intelligently ensures the exchange of electrical energy from various sources with consumers of different demand characteristics by incorporating measurement and mostly digital information and communication technologies. Such a system should take into account the needs of all market

Effects of a smart grid on measurement technology

Basically, the common measurement data of voltage, current and frequency as well as their derived quantities are still required. However, and here comes the possible challenge for the smart grid application: The metering data will be combined and related to new customer needs

In addition, it certainly makes sense to continue to use analog indicators (electro-mechanical) redundantly for essential functions. These will withstand any failure and/or attack of a data communication. This is also very clear from the matrix shown below.

Classical distinction matrix of measuring devices in the context of application

Terminology:	Analog Indicator	Energy Meter	Transducer	Power Metering and Monitoring Devices	Power Quality Instruments
Short:	AM	EM	TRD	PMD	PQI
IEC Standard:	IEC 60051	IEC 62053-2x	IEC 60688	IEC 61557-12	IEC 62586-1
Example:					
Legal Billing		✓			
Energy Management		✓		✓	✓
Energy Monitoring, Power Monitoring, Plant Engineering	✓		✓	✓	✓
Power Quality Monitoring				✓	✓
Smart Grid	✓	✓	✓	✓	✓



THE NEED FOR TRANSPARENCY

Distribution system operators have a contractual obligation to provide their customers with energy in the agreed quantity and quality. In order for them to be able to verify compliance with these services, «transparency in the cable» must first

be established. With the information about the current load flows, these become controllable at network level (6) 7 and thus also enable efficient utilization of the grid quality limits. The aim here is to be able to avoid expensive grid expansion

and the associated high costs. This also promotes the issue of general resource conservation (e.g., dispensing with additional quantities of copper).

Schematic representation

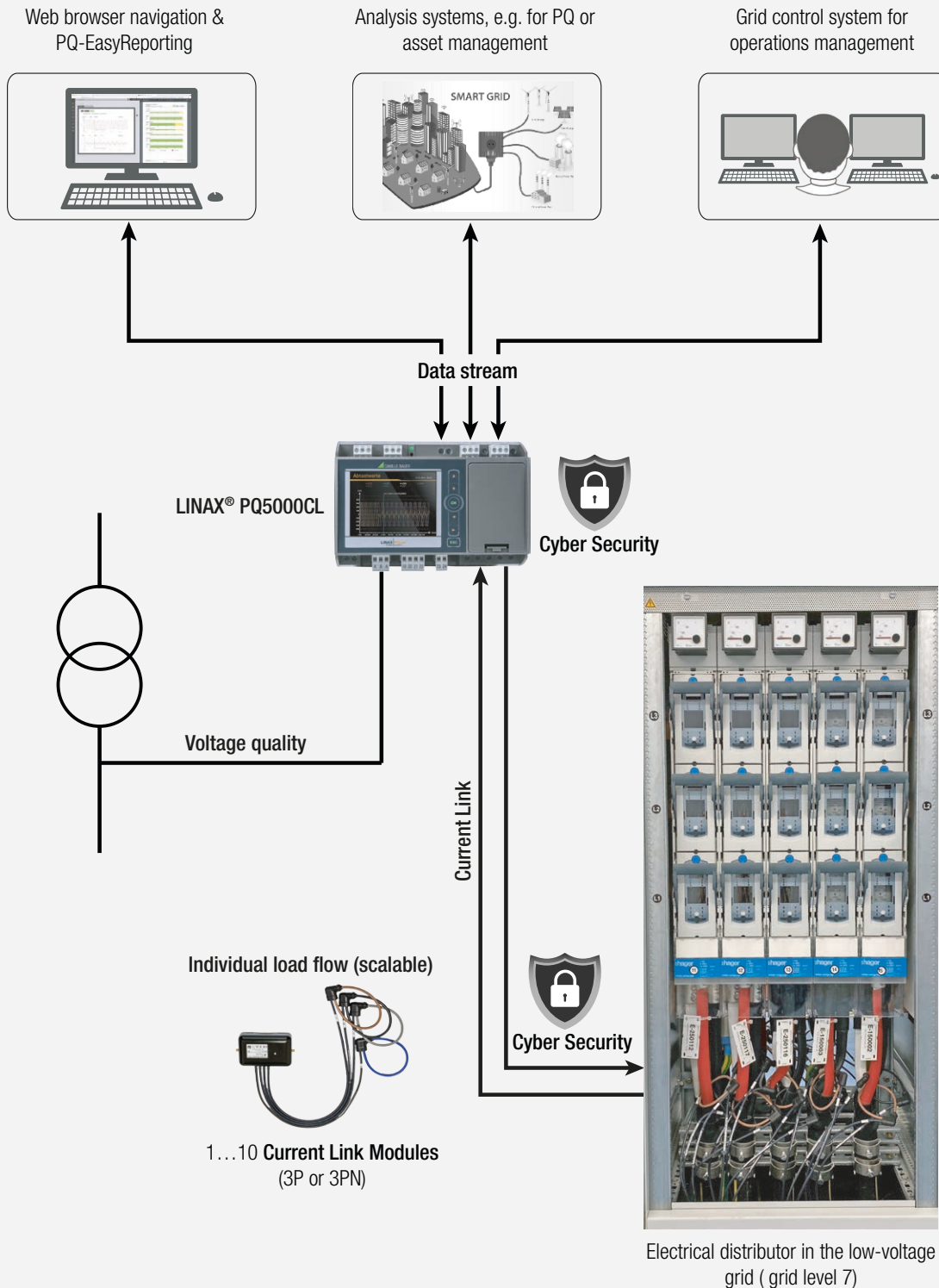

Electrical distributor in the low-voltage grid (grid level 7)



THE BASIS: A METROLOGICAL COMPASS

Fundamental measurement technology from the «bottom up» forms the basis for cellular energy systems and thus also smart grids in order to be able to stabilize grids (e.g. due to prosumer behavior, switching off grid mass, etc.). Here, not only scalability is important, but also absolute future viability, e.g., through flexible connectivity, function adaptations, etc.

We propose a certified power quality measurement and power analysis up to 32 channels in the sub-distribution. The signal processing

is implemented on the measuring device of the LINAX® PQ5000CL series. There, the respective current measured values of the so-called Current Link modules are processed. Thanks to the Current Link technology, the individual Current Link modules and their sensors (Rogowski) are networked in a scalable manner by means of a signal loop via coaxial cables. This reduces the installation effort to an absolute minimum and ensures proper cable routing. In addition, this measuring system for determining power quality

and load flows is extremely cost-efficient and metrologically certified on top. Thus, the scalable measuring instrument virtually combines the areas of transducers according to IEC 60688, power metering and monitoring according to IEC 61557-12 as well as power quality instruments according to IEC 62586-1.

LINAX® PQ5000CL

- Metrologically certified PQI according to IEC61000-4-30 Ed. 3 class A as basic device
- A scalable system for the areas of certified power quality as well as for load and efficiency management for up to 10 feeders (32 lines)
- Monitoring of feeders with 3 or 4 currents using 3P/3PN Current Link modules (max. 32 currents)
- Simultaneous measurement of multiple feeders instead of traditional per feeder measurement
- Direct compliance reporting and event display by PQEasy reporting via web browser (e.g. according to EN50160)
- Disturbance recordings for voltage events
- Time synchronous load management for U/I/P/Q/PF
- Current measurement per Current Link channel «IN1 (typical/maximum) of 400 A / 1'000 A» and «IN2 (typical/maximum) of 8'000 A / 20'000 A»
- Grid tariff meter P & Q (purchase & delivery)
- System management by means of a user-friendly multi-device tool for easy commissioning and efficient maintenance
- Low space requirement due to single voltage measurement
- No need to shut down the plant for installation of the measuring system due to the non-invasive Rogowski measuring technique
- Very high robustness due to proven coaxial principle
- Current values are time synchronous to voltage (IEC61000-4-30)
- Various communication interfaces (Modbus TCP/IP, Modbus RTU, REST API, IEC61850, Cloud with MQTT, Webbrowser) allow high connectivity flexibility to parallel as well as higher-level systems
- Fast installation with robust measurement technology
- Sampling rate 54 kHz

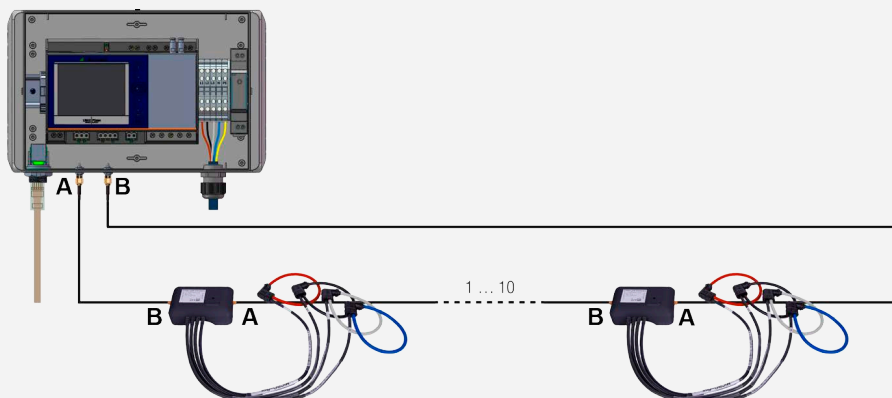
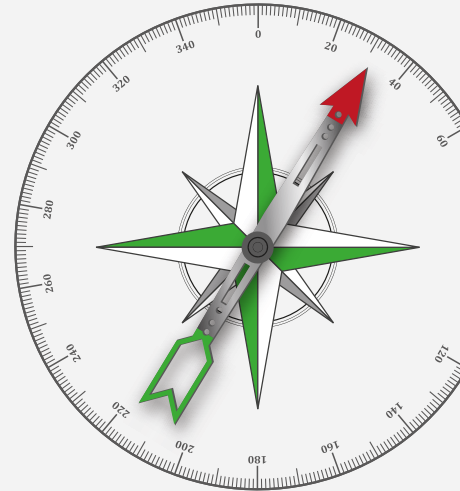

LINAX® PQ5000CL-3 in field housing with connected Current Modules 3PN



Special versions only on request and for large quantities

	PQ5000CL - DIN rail mounting	PQ5000CL - Field housing
Voltage inputs Current inputs of the Current Modules Function class according to IEC 61000-4-30 Device type according to IEC 62586-1 Number of Current Link Modules	4 up to 32 Class A PQI-A FI1 up to 10	4 up to 32 Class A PQI-A FI1 up to 10
PQ COMPLIANCE MONITORING Mains frequency Voltage changes Unbalance voltage / current THDS of mains voltages Harmonic voltage / current Flicker Pst / Pit Signal transmission voltages Interharmonic voltage	<ul style="list-style-type: none"> ▪ ▪ ▪ ▪ ▪ ▪ ▪ ▪ 	<ul style="list-style-type: none"> ▪ ▪ ▪ ▪ ▪ ▪ ▪ ▪
PQ EVENT RECORDING Voltage dip Voltage interruption Voltage swell Rapid Voltage Change (RVC) Homopolar voltage (unbalance) Frequency anomaly Ripple control sequences	<ul style="list-style-type: none"> ▪ ▪ ▪ ▪ ▪ ▪ ▪ 	<ul style="list-style-type: none"> ▪ ▪ ▪ ▪ ▪ ▪ ▪
MEASUREMENT UNCERTAINTY Voltage Current Current Module 3P/3PN Power Current Module 3P/3PN Active energy Current Module 3P/3PN	±0,1% ±0,5% ±2.0% (typical) Class 3 (typical)	±0,1% ±0,5% ±2.0% (typical) Class 3 (typical)
COMMUNICATION Ethernet: Modbus/TCP, Webserver, NTP IEC 61850 MQTT Modbus /RTU	(Standard) (Option) (Option) (Standard)	(Standard) (Option) (Option) –
AUXILIARY ENERGY Power consumption	100...230V AC 50/60Hz / DC ±15% Separate 24 VDC supply required for Current Link ≤ 27VA, ≤ 12W	100...230V AC 50/60Hz /(internal) – ≤ 60VA
STRUCTURE Color display (optional) Dimensions Mounting	TFT 3,5" (320x240px) 160 x 110 x 70 mm DIN rail	TFT 3,5" (320x240px) 271 x 170 x 90 mm Wall mounting



CERTIFIED POWER QUALITY MONITORING



- Independent certification by the Swiss Federal Institute of Metrology according to IEC 62586-2 (standard for testing compliance with IEC 61000-4-30)
- Proven at 230V / 50 Hz and 120V / 60Hz
- Flicker meter class F1
- Marking concept: Multiphase approach according to IEC 61000-4-30

The LINAX® PQ5000CL is a class A device according to IEC 61000-4-30 and can thus serve as a reliable and comparable source of information for regulatory authorities, for negotiations with energy suppliers or for internal quality control.

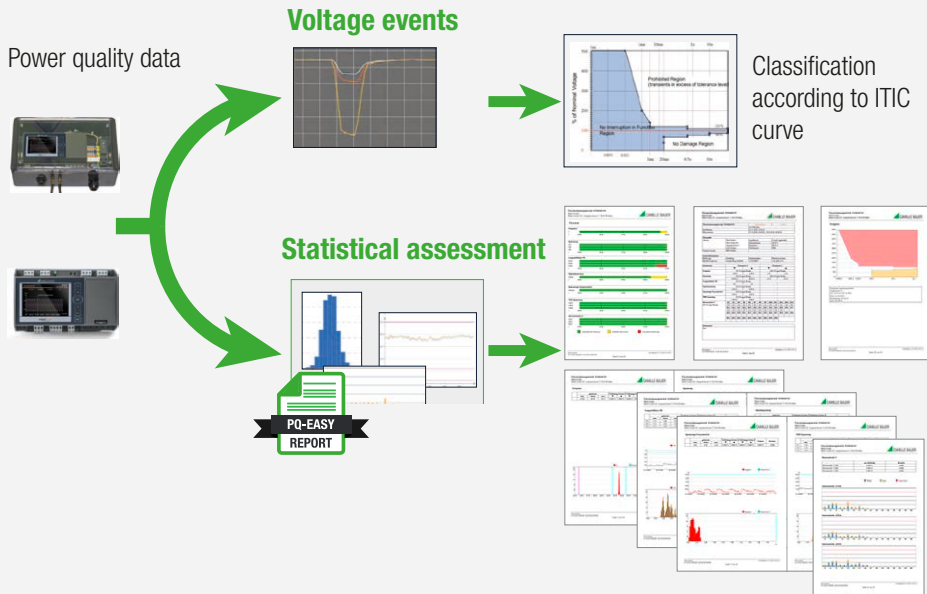

- Preparation of reports via the device web interface
- Tamper-resistant PDF format
- Selectable report duration
- Selectable report scope (overview, statistic details, event overview)
- Direct compliance assessment of standards EN 50160, IEC 61000-2-2 / 2-4 / 2-12 or customer specific limits
- Customer specific logo in the report

POWER QUALITY DATA ANALYSIS

All of the Power Quality data acquired by the device can be directly visualised and analysed via the device website. Additional software is not required.

Power Quality events

- Power Quality event list with trigger source, event type, event duration and characteristic event values
- Direct display of event details by selecting an entry in the event list: Measured value progressions of RMS $\frac{1}{2}$ values for all voltages with time zoom and value display
- Recording of ripple control sequences to verify the ripple control level and pulse sequences at the receiver

Power Quality statistics

- Overview of conformity with a selectable standard. Depending on the standard selected, more or less criteria are taken into consideration.
- Daily progressions of all acquired PQ trend values, display with/without limit values and fluctuation range
- PQ easy report: Preparation of a conformity report (pdf format) of a selectable extent

Using the data export options and due to standardised formats like PQDIF, the analysis of PQ data can also be delegated to software solutions like SmartCollect® SC² or freely available viewers like PQDiffactor of Electrotek Concepts may be used.

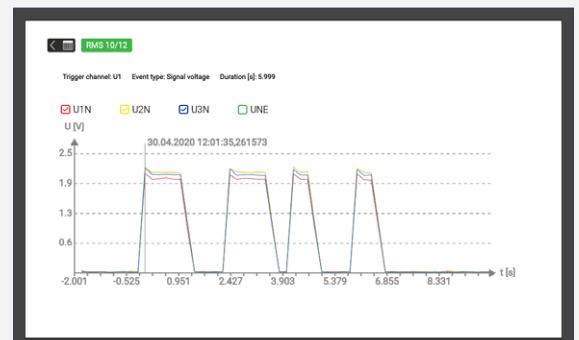

Ripple control sequence acquired as an event

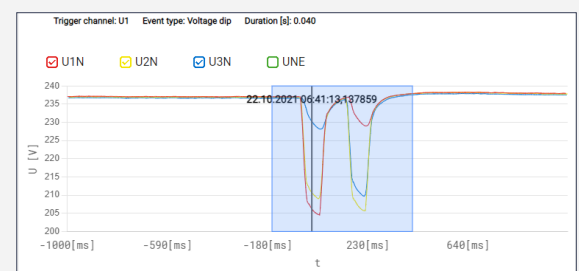

RMS $\frac{1}{2}$ recording of an event with zoom option



DATA EXPORT

Automated

Measured value information may not only be monitored directly but can also be saved in files in the device or forwarded to an SFTP server using a data export scheduler. The following file types are supported:

- PQDIF for event-controlled forwarding / saving of PQ event recordings
- PQDIF for periodic forwarding / saving of all PQ data (trends and events)

There are predefined tasks for the creation of the PQDIF files, which may be adapted to individual needs and linked to the actions «store on local storage» and «send to SFTP server». Files stored locally in the device may be transferred to a computer via the device website or the REST interface. If these files are not required, their creation can also be disabled.

The Secure File Transfer Protocol (SFTP) facilitates the encoded transfer of files. It may also be used for the transmission of measured value information via secured network structures, e.g. via Smart Meter Gateways.

Manually

If no network structure is available, it may make sense to prepare files manually via the device website and to save them on the PC:

- CSV files: For event lists and PQ event recordings
- PQDIF files of all PQ data for a selectable time range of 1 up to 7 days

Edit task

Name: Periodic PQDIF

File: PQDIF (dropdown) | Everything in one file (dropdown)

Creation: daily (last 7 days) (dropdown), daily (last 24 hours) (dropdown), **daily (last 7 days)** (selected), weekly (last 7 days) (dropdown)

Action: store on local Storage (dropdown)

push to SFTP server (dropdown)

subfolder: PQDIF_data (text input)

Transmission window: none (dropdown)

Ok Cancel

Task for daily saving / forwarding PQDIF data for the last 7 days

File formats

- **CSV**: Comma Separated Value
- **PQDIF**: Power Quality Data Interchange Format acc. IEEE 1159.3

OPERATION

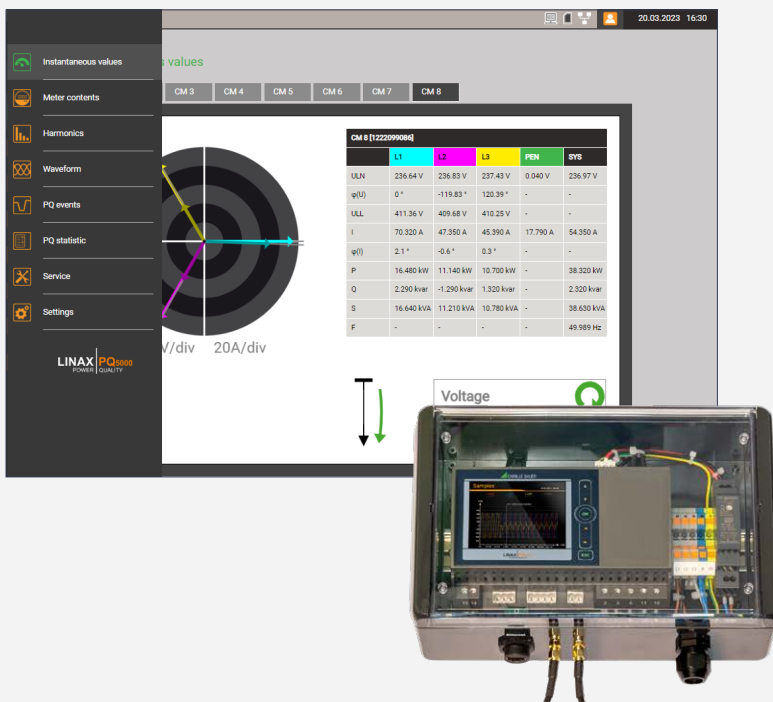

OPERATION

The local operation at the device itself and the access via web interface are structured identically.

The access to

- Measured data
- Service functions
- Settings of the measuring device

can thus be intuitively effected via a topically arranged, language-specific menu structure.

The extent of the indicated menu structure may be different for the local display and the device website, if this has been respectively determined via the access control system (RBAC). It might also be necessary that users first log in order to have a menu displayed.

The top-right status bar informs on the current states of alarm monitoring as well as network, access control system, data memory and UPS and also indicates the time and date of the device.



COMMISSIONING AND SERVICE

The device provides versatile tools for safe and easy commissioning and maintenance. Some are listed below:

Vector diagram / Phase sequence indicator / Energy direction

With these displays, you can easily verify whether the measuring inputs have been correctly connected. Non-conforming rotational directions of voltages and currents, reverse polarity current connections and interchanged current or voltage connections are immediately recognised.

Communication tests

Permit the verification of effected network settings and provide quick answers to these questions:

- Can the gateway be reached?
- Can the URL of the NTP server be cancelled via DNS?
- Is NTP a time server and is the time synchronisation working?
- Does the data storage on the SFTP server work?

Operating instructions

The operating instructions are stored in the device as a PDF file and can be opened in the browser or downloaded to a PC at any time. The instructions are respectively updated in any firmware update thus always documenting the implemented state.

Deletion of data

Recordings of measured data may be selectively deleted or reset. Every one of these activities can be protected via the Role Based Access Control system (RBAC) and is logged with the user identification upon execution.

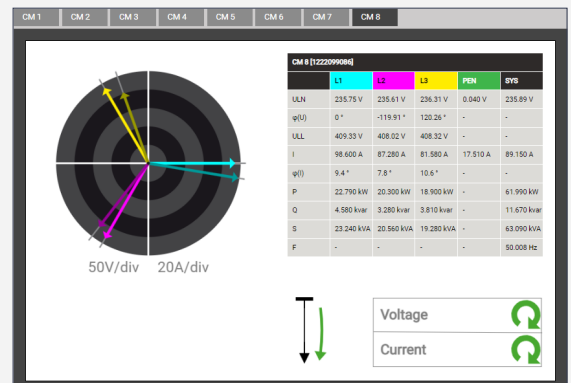

Vector diagram to control connections

IPv4: Ping 192.168.56.4 Test

IPv6: Ping fd2d:bb44:97f1:3976::5:1 Test

DNS 192.168.56.55 ntp.metas.ch Test

NTP ntp.metas.ch Test

SFTP server tenserv.camillebauer.intra 22 data sftpuser **** Test

Communication tests: Control of network structure

ADVANTAGES OF COAXIAL LINES

Coaxial cables are two-pole cables with a concentric structure. They consist of an inner conductor (also called core), which is surrounded at a constant distance by a



hollow cylindrical outer conductor. The outer conductor shields the inner conductor from interference radiation. Coaxial lines are suitable for transmitting high-frequency, broadband signals in the frequency range from a few kHz to a few GHz. Due to their physical properties and simple nature, coaxial lines are very well suited for scalable current link technology. The high-frequency signals are transmitted cleanly and with high performance. In addition, interference from outside as well as interference to the outside is very well shielded. The coaxial technology also makes it possible to set up ring lines with a maximum total length of 20m as a „quasi-bus“, which in turn reduces the wiring effort enormously. The auxiliary

power supply of the Current Link modules and the signals are transmitted in one cable. This eliminates the need to feed many confusing individual cables into a distribution cabinet. In addition, the existing IT infrastructure is not additionally burdened, since the hard cabling is insensitive to radio signals. Hacker attacks via or even into the ring bus are also eliminated.



ONE MEASURING SYSTEM COVERS EVERYTHING

Traditionally, one measuring device for load flow measurement with current transformer or Rogowski coil is installed per 3P (L1-L2-L3) or 3PN (L1-L2-L3-N). In the case of transparency in the smart grid, for a system with 8 loads (feeders), this would mean that 8 measuring devices would also have to be used. The installation effort (e.g. 8 x 4 measuring inputs for voltage & current, 8 x supply voltage, 8 x costs for a measuring device & accessories, 8 x installation, etc.) as well as the often unavailable installation space is a problem.

Last but not least, the IT infrastructure is also burdened, since either complete Modbus RS485 networks have to be set up or many new IP addresses have to be managed in the patch. Not to forget the high effort for individual cyber protection, connectivity and general device administration. In addition, it must be ensured that all measuring devices used measure time-synchronized on all channels. And if you now want to put the power quality, e.g., according to EN50160 and an additional event monitor, into context as well, the costs and the effort then explode completely.

In the LINAX® PQ5000CL system, everything has been integrated into one system. This is a scalable current measurement via the Current Link Modules, in combination with the metrologically certified power quality monitoring of class A in the base unit. A metrological compass, so to speak. For the calculation of the power quantities for each feeder, the measurement of the individual current channels of the Current Link modules is synchronized to the acquisition of the voltages in the base unit. In case of an event all voltages are recorded both as half-cycle and waveform recording!

Thereby, the IT infrastructure is only minimally burdened, since only one participant as data concentrator takes over the consolidation and communication of all measurement data. And not to forget, the unique cyber protection on device level, which contributes significantly to the overall cyber security in the network operation.

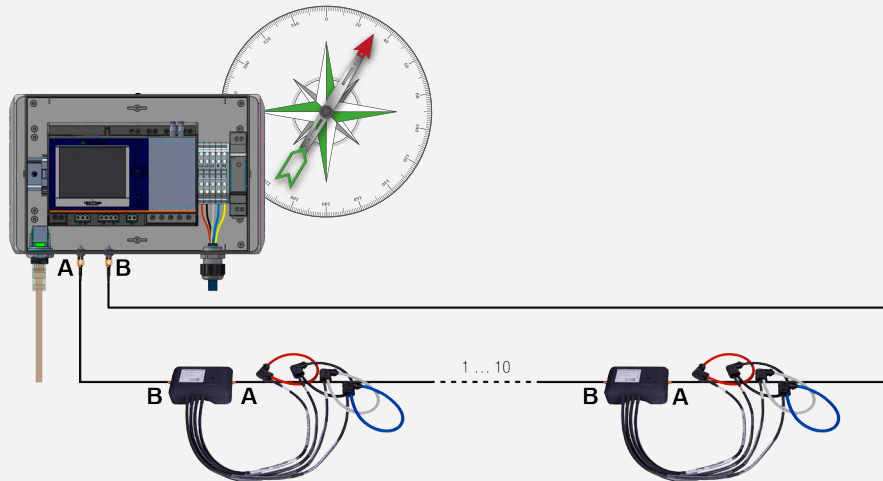

Gapless measurement

Due to the high sampling rate (18kHz (U) / 54kHz (I)), virtually nothing remains hidden and even quick fluctuations are recorded without gaps at any time. This is important in order to provide automation (e.g. digital grid management) with high-performance, but also real data, or to create unique transparency in the smart grid (e.g. real-time digital twin). Here, the transfer of the measurement data to the base unit takes place via the coaxial ring bus system, and from there the consolidated measurement data is transferred to the parallel or higher-level system.

Automatic range switching up to 20'000A

Each Current Link module (3P or 3PN) has the possibility to be used individually in a typical rated current range according to the "Factor20 technology". Thereby, rated currents are automatically categorized by the Current Link modules into the ranges "IN1 (typical/maximum) of 400A/1'000A" and "IN2 (typical/maximum) of 8'000A/20'000A". This means that each module can measure permanently up to a maximum of 20'000A. This is helped by an automated range switching feature integrated in the Current Link modules. This type of functionality is optimally suited for operating a Current Link system on a variety of asymmetrical or balanced loads with different nominal currents.





EXAMPLE WITHOUT TOTAL CURRENT MEASUREMENT

(primarily for EN50160 compliance)

Principle of the metrological smart grid compass

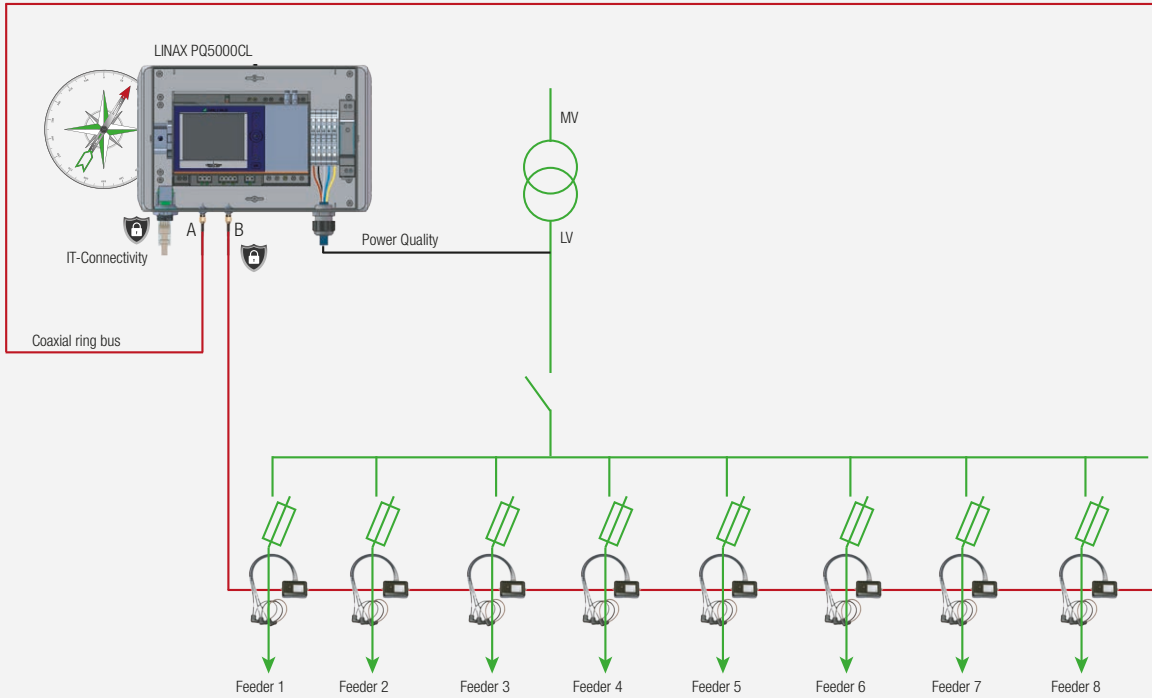

Variant 1: In field housing for wall mounting (built-in power supply for Current Link modules)

Principle of the metrological smart grid compass

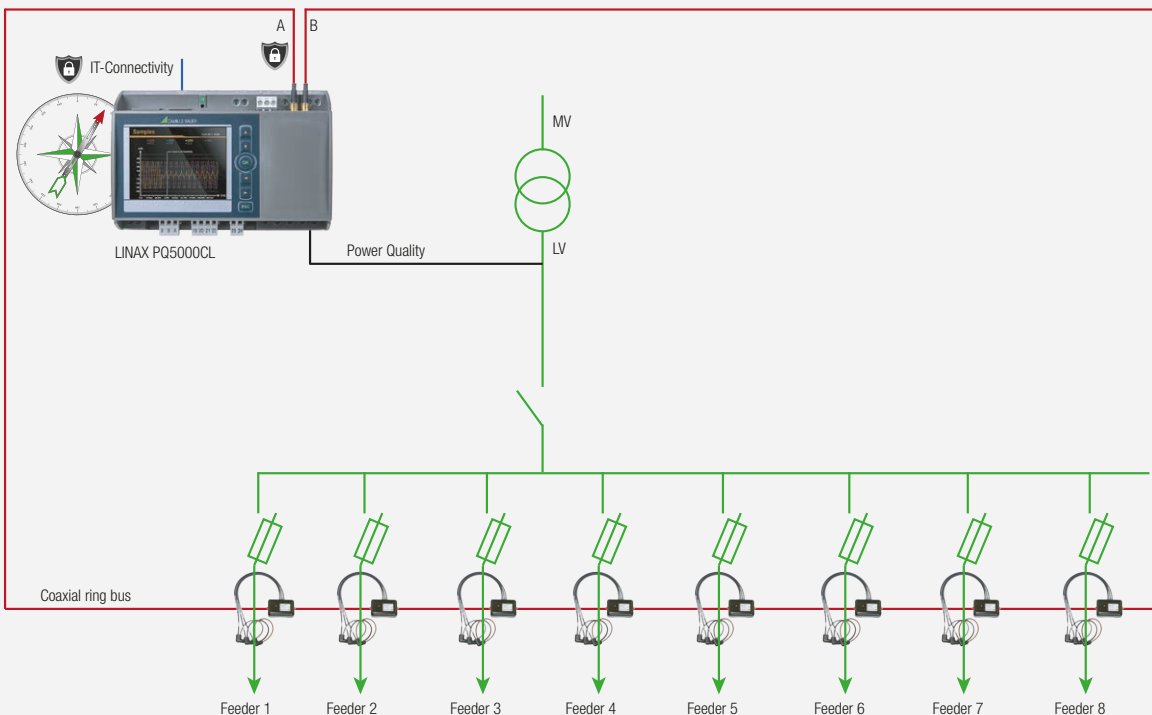

Variant 2: Top-hat rail mounting (additional power supply for Current Link modules required)



EXAMPLE WITH TOTAL CURRENT MEASUREMENT

Principle of the metrological smart grid compass

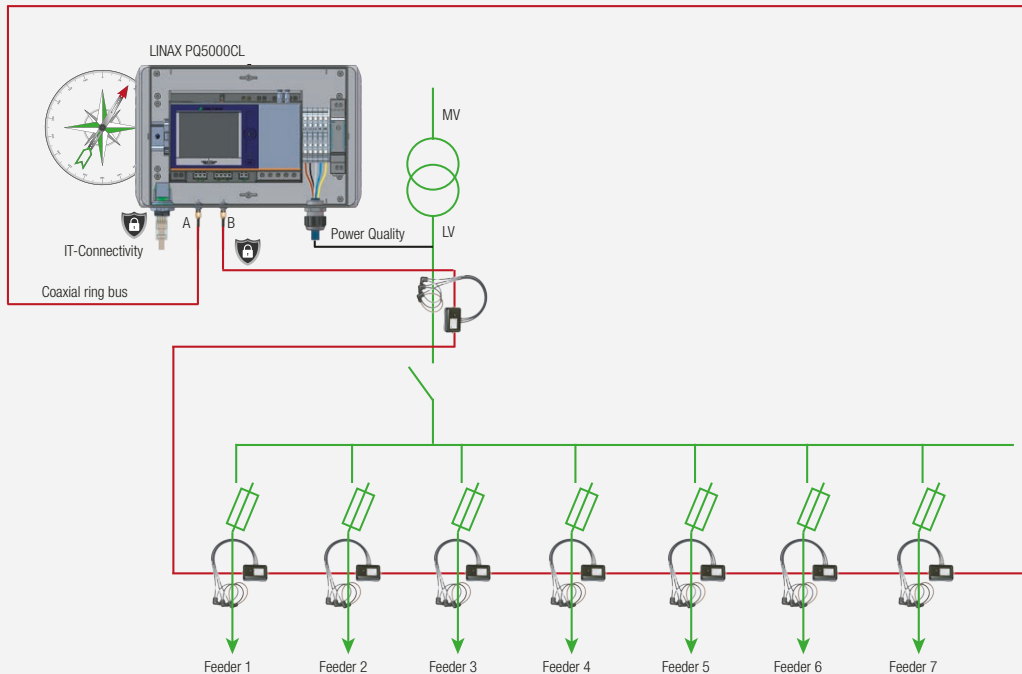

Total busbar current measured using the first Current module

Flexible connectivity to higher-level as well as parallel systems

A major challenge is always the connectivity to existing superior systems. In addition to the communication protocol itself, it must be determined which measurement data is really relevant and how often it should be updated on system level. And last but not least, there is the question of a data pull or a data push. The LINAX® PQ5000CL system offers the possibility of connection via the IEC 61850 protocol. For this, approx. 35 measurement values per Current Link module are sent to the higher-level system via a data push in the “top-of-second procedure”, i.e. once per second. The big advantage of this method is that the measurement data of all monitored measuring points from any number of measuring devices is on the same time basis, this way reflecting the current load situation in a possibly large grid.

However, not every control system supports IEC 61850 communication yet. For this reason, proven protocols such as Modbus/RTU and Modbus/TCP are supported by the LINAX® PQ5000CL. And since the implementation of a smart grid is typically done in a specific grid management system (e.g. by Venios Energy Solution, Fichtner Digital Grid, etc.), protocols like MQTT become more relevant to ensure direct communication without a gateway and in real-time (planned in 2023). The LINAX® PQ5000CL system also provides the measurement data via the REST API.

Comprehensive cyber protection at field level

Cyber security, especially in critical infrastructure, is fundamental. Currently, it is reported that everywhere, not only in this specific area, attacks are increasing and doing their destructive work faster (e.g. Ransomware Lockbit 3.0, etc.). And that's why any unprotected access (e.g. LAN ports, USB ports, SD ports, etc.) is also a potential risk. So do the connectivity variants of a measuring device. Be it via IT or even via the HMI. Imagine the many measurement data on the low voltage level, are manipulated. Intentionally or unintentionally. The result is pure chaos.

To counteract this, specific protection mechanisms have been implemented directly in the measuring instrument. The protection mechanisms currently include secure communication via IEC61850, support for HTTPS, the audit log (logbook of all processes that affect security and data consistency), management of access authorizations (RBAC) at various levels, the client whitelist and the transfer of the audit log entries via syslog protocol to a central server. In addition, the possibility of wireless communication via VPN gateway can be considered (attention: data volume/time unit).



CYBER PROTECTION IN THE MEASURING DEVICE

Critical infrastructures - and this undoubtedly includes the supply of electrical energy - are increasingly the target of cyber attacks. There is not only the attempt of stealing data by unauthorised access or eavesdropping of communication but also the limitation or even interruption of the energy supply by manipulating data or data traffic.

A comprehensive security concept on plant level comprising each grid component is required to repel such attacks. The security mechanisms integrated into LINAX® PQ5000CL support such concepts, thus contributing to a secure supply of energy.

SECURITY MECHANISMS

- **Role-Based Access Control (RBAC):** Allows different users to be granted individual rights or to restrict them to those activities that correspond to their role. Each available menu item, whether measured value, setting value or service function, can thus be displayed, hidden, changeable or locked. As soon as the RBAC is active, even software can only access data of the device via access keys. During the login process, information is never transmitted in plain text, and the latency time is constantly increased in the event of repeated, unsuccessful login attempts.
- **Encoded data transmission via HTTPS** using root certificates
- **Audit log:** Logging of all activities relevant to security. Transfer option to central grid monitoring server by Syslog.
- **Client white list:** Limitation of computers with access authorization
- **Digitally signed firmware files** for secure updates
- **Data logger & Uninterruptible Power Supply (UPS)**
 - SD card memory
 - 16 GB data memory lasts for many years in typical operation
 - UPS with 5×3 minutes in case of power failure on the supply
- **Data export**
 - Manual data export via CSV & PQDIF
 - Automated data export CSV & PQDIF (scheduler)
 - Event push (PQDIF) to the SFTP server
- **Secure connection via gateway**
 - VPN Cloud-Service
 - Mobile phone connection

Metrologically certified measuring system

- METAS Certificate (Swiss Federal Institute of Metrology)
- Certified power quality according to IEC 61000-4-30 Ed.3, Class A
- Certified active energy class 0.2S

Filter: Emergency Alert Critical Error Warning Notice Info Debug

Time	PID	Priority	IP address	User name	Message
13.01.2021, 14:38:03	cb-gui	Info	192.168.57.69:49270	admin	User logged out successfully
13.01.2021, 14:22:47	cb-gui	Notice	192.168.57.69:63931	admin	User reviewed latest security event log (allow)
13.01.2021, 14:22:32	cb-gui	Notice	192.168.57.69:63933	admin	User logged in successfully
13.01.2021, 14:20:28	cb-gui	Notice	192.168.57.69:63790	anonymous	User reviewed latest security event log (allow)
13.01.2021, 14:07:31	cb-gui	Info	195.49.116.212:62261	admin	User has been logged out due to inactivity
13.01.2021, 13:47:51	cb-gui	Notice	195.49.116.212:60235	admin	User reviewed latest security event log (allow)
13.01.2021, 13:23:11	cb-gui	Notice	195.49.116.212:60136	admin	User logged in successfully
07.01.2021, 11:51:09	cb-gui	Warning	46.126.246.147:1436	admin	Failed login attempt# 3
07.01.2021, 11:49:39	cb-gui	Warning	46.126.246.147:1417	admin	Failed login attempt# 2
07.01.2021, 11:49:30	cb-gui	Warning	46.126.246.147:1419	admin	Failed login attempt# 1
29.12.2020, 10:49:27	cb-gui	Notice	223.186.41.211:5122	anonymous	User reviewed latest security event log (allow)

Audit log with filter option

	admin	localgui	anonymous	Operator1	Operator2	Operator3	[API]AccessKey
Local account (no weblogin)	<input type="checkbox"/>	<input checked="" type="checkbox"/>	<input type="checkbox"/>	<input type="checkbox"/>	<input type="checkbox"/>	<input type="checkbox"/>	<input type="checkbox"/>
Instantaneous values	<input checked="" type="checkbox"/>	<input checked="" type="checkbox"/>	<input checked="" type="checkbox"/>	<input checked="" type="checkbox"/>	<input checked="" type="checkbox"/>	<input checked="" type="checkbox"/>	<input checked="" type="checkbox"/>
Energy	<input checked="" type="checkbox"/>	<input checked="" type="checkbox"/>	<input checked="" type="checkbox"/>	<input checked="" type="checkbox"/>	<input checked="" type="checkbox"/>	<input checked="" type="checkbox"/>	<input checked="" type="checkbox"/>
Harmonics	<input checked="" type="checkbox"/>	<input checked="" type="checkbox"/>	<input checked="" type="checkbox"/>	<input checked="" type="checkbox"/>	<input checked="" type="checkbox"/>	<input checked="" type="checkbox"/>	<input checked="" type="checkbox"/>
Phasor diagram	<input checked="" type="checkbox"/>	<input checked="" type="checkbox"/>	<input checked="" type="checkbox"/>	<input checked="" type="checkbox"/>	<input checked="" type="checkbox"/>	<input checked="" type="checkbox"/>	<input checked="" type="checkbox"/>
Waveform	<input checked="" type="checkbox"/>	<input checked="" type="checkbox"/>	<input checked="" type="checkbox"/>	<input checked="" type="checkbox"/>	<input checked="" type="checkbox"/>	<input checked="" type="checkbox"/>	<input checked="" type="checkbox"/>
Events	<input checked="" type="checkbox"/>	<input checked="" type="checkbox"/>	<input checked="" type="checkbox"/>	<input checked="" type="checkbox"/>	<input checked="" type="checkbox"/>	<input checked="" type="checkbox"/>	<input checked="" type="checkbox"/>
PQ statistic	<input checked="" type="checkbox"/>	<input checked="" type="checkbox"/>	<input checked="" type="checkbox"/>	<input checked="" type="checkbox"/>	<input checked="" type="checkbox"/>	<input checked="" type="checkbox"/>	<input checked="" type="checkbox"/>
Service	<input checked="" type="checkbox"/>	<input checked="" type="checkbox"/>	<input checked="" type="checkbox"/>	<input checked="" type="checkbox"/>	<input checked="" type="checkbox"/>	<input checked="" type="checkbox"/>	<input checked="" type="checkbox"/>
Reset values	<input checked="" type="checkbox"/>	<input checked="" type="checkbox"/>	<input checked="" type="checkbox"/>	<input checked="" type="checkbox"/>	<input checked="" type="checkbox"/>	<input checked="" type="checkbox"/>	<input checked="" type="checkbox"/>
Reset/Update device	<input checked="" type="checkbox"/>	<input checked="" type="checkbox"/>	<input checked="" type="checkbox"/>	<input checked="" type="checkbox"/>	<input checked="" type="checkbox"/>	<input checked="" type="checkbox"/>	<input checked="" type="checkbox"/>
Audit Log	<input checked="" type="checkbox"/>	<input checked="" type="checkbox"/>	<input checked="" type="checkbox"/>	<input checked="" type="checkbox"/>	<input checked="" type="checkbox"/>	<input checked="" type="checkbox"/>	<input checked="" type="checkbox"/>
Use IO simulation	<input checked="" type="checkbox"/>	<input checked="" type="checkbox"/>	<input checked="" type="checkbox"/>	<input checked="" type="checkbox"/>	<input checked="" type="checkbox"/>	<input checked="" type="checkbox"/>	<input checked="" type="checkbox"/>
Settings	<input checked="" type="checkbox"/>	<input checked="" type="checkbox"/>	<input checked="" type="checkbox"/>	<input checked="" type="checkbox"/>	<input checked="" type="checkbox"/>	<input checked="" type="checkbox"/>	<input checked="" type="checkbox"/>
Basic device settings	<input checked="" type="checkbox"/>	<input checked="" type="checkbox"/>	<input checked="" type="checkbox"/>	<input checked="" type="checkbox"/>	<input checked="" type="checkbox"/>	<input checked="" type="checkbox"/>	<input checked="" type="checkbox"/>
Measurement	<input checked="" type="checkbox"/>	<input checked="" type="checkbox"/>	<input checked="" type="checkbox"/>	<input checked="" type="checkbox"/>	<input checked="" type="checkbox"/>	<input checked="" type="checkbox"/>	<input checked="" type="checkbox"/>
Communication	<input checked="" type="checkbox"/>	<input checked="" type="checkbox"/>	<input checked="" type="checkbox"/>	<input checked="" type="checkbox"/>	<input checked="" type="checkbox"/>	<input checked="" type="checkbox"/>	<input checked="" type="checkbox"/>
Security system	<input checked="" type="checkbox"/>	<input checked="" type="checkbox"/>	<input checked="" type="checkbox"/>	<input checked="" type="checkbox"/>	<input checked="" type="checkbox"/>	<input checked="" type="checkbox"/>	<input checked="" type="checkbox"/>

RBAC access rights of different users



JUST SCREWED TO THE WALL

The LINAX® PQ5000CL system can traditionally be mounted in the control cabinet on a DIN rail. Often, however, there is no more space in the existing systems and the effort of setting up a new control cabinet is out of proportion. So why not simply screw the base unit to the wall. Exactly for this case, the base unit was installed in a IP66 housing and completely wired, including the necessary power supply of the Current Link modules. Mount, connect, done.



FASTEST INSTALLATION

The Current Link System not only takes into account the extremely high measurement and data performance, but also the uncomplicated hardware installation and software integration. The complete current measurement technology can be installed virtually during operation of the system. The non-invasive Current Link Modules with Rogowski technology on the measurement loops ensure a smooth, yet safe installation. Due to the coaxial ring bus cable, no additional and costly installation work is

required. Not least because the Current Link modules are also supplied with the necessary operating voltage via the ring bus cable. If you also opt for the integrated variant in the IP66 housing, there is even no need for additional wiring in a control cabinet. And since the basic device already functions as a data concentrator, complex measured value integrations in the IT environment are reduced many times over.

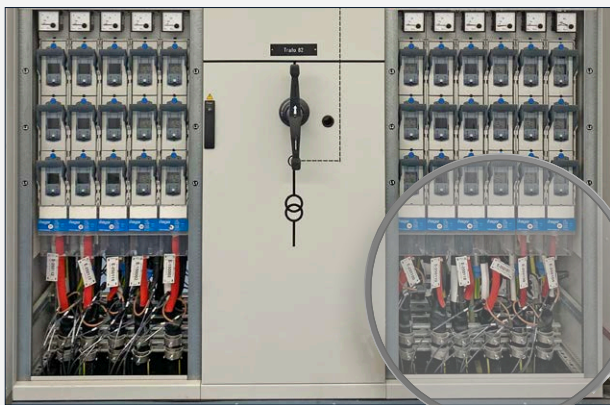

Structure of a switchgear in the front view



Installed Current Link modules per feeder

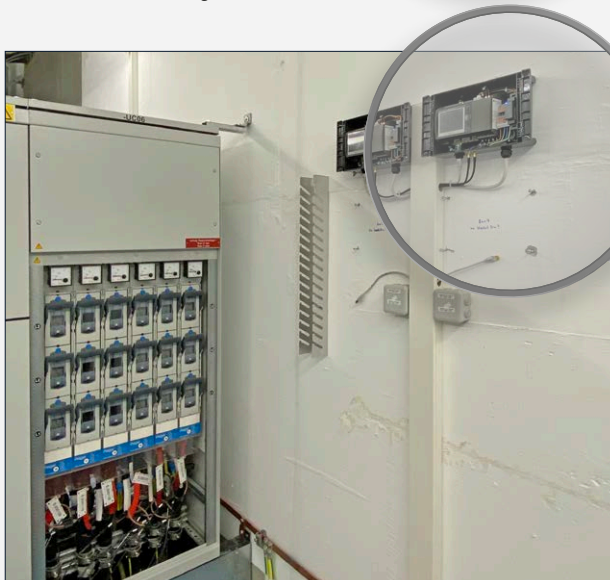

Representation of the switchgear and the decentrally mounted LINAX® PQ5000CL base stations



Detailed view of the decentralized mounted base stations LINAX® PQ5000CL



TECHNICAL DATA PQ5000CL

Some of the technical features are only available on request.

MEASURING INPUTS

VOLTAGE BASE UNIT PQ5000CL-0/-1

Rated voltage:	57,7...400 V _{LN} (UL: 347 V _{LN}), 100...693 V _{LL} (UL: 600 V _{LL});
Measuring range max:	520 V _{LN} , 900 V _{LL} (Sinus)
Measurement category:	600V CAT III
Measurement uncertainty:	± 0,1%
Self-consumption:	≤ U ² / 1,54 MΩ per phase
Impedance:	1,54 MΩ per phase
Overload capacity:	permanent: 520 V _{LN} , 900 V _{LL} 10 x 1 s, Interval 10s: 800 V _{LN} , 1386 V _{LL}

VOLTAGE BASE UNIT PQ5000CL-2/-3

Rated voltage:	100...230 V _{LN} , 173...400 V _{LL}
Measuring range max:	265 V _{LN} , 460 V _{LL} (Sinus)
Measurement category:	300V CAT III
Measurement uncertainty:	± 0,1%
Self-consumption:	≤ U ² / 1,54 MΩ per phase
Impedance:	1,54 MΩ per phase
Overload capacity:	Interval: 265 V _{LN} , 460 V _{LL}

CURRENT LINK MODUL 3P / 3PN

Measurement range 1:	400 A (typ.), 1000 A (max.)
Measurement range 2:	8 kA (typ.), 20 kA (max.)
Measurement category:	600V CAT IV
Measurement uncertainty:	± 0,5% (with centered conductor and without external field)
Angular error:	± 1,0°
Design:	3 or 4 Rogowski coils
Housing:	Polycarbonate (Makrolon) with impact test according to IEC61010-1, chapter 8
Diameter:	approx. 8mm (Rogowski coil)
Loop diameter:	75 or 100mm (Rogowski coil)
Connection:	SMA connecting lines
Communication:	Coaxial ring bus with max. 20m

MEASUREMENT UNCERTAINTY

Reference conditions: According to IEC/EN 60688, environment 23°C±1K, sinusoidal input, Rogowski current measurement with centered conductor and without external field.

Quantity	Current-Modul 3P / 3PN
Voltage	± 0,1 %
Current	± 0,5 %
Performance	± 2,0 % (typical)
Power factor	± 1,0°
Frequency	± 0,01 Hz
Active energy	Class 3 (typical)
Reactive energy	Class 3 (typical)

CONNECTION TYPE: 4-wire, unbalanced load

NOMINAL FREQUENCY: 42...50...58Hz

SAMPLING RATE: 18 kHz (U), 54 kHz (I)

DATA MEMORY INTERNAL: 16 GB

POWER SUPPLY

	via terminals 13-14 (PQ5000CL-0/-1), internal (PQ5000CL-2/-3)
Nominal voltage:	100...230V AC 50/60Hz / DC ±15% (PQ5000CL-0/-1) 100...230V AC 50/60Hz ±15% (PQ5000CL-2/-3)
Overvoltage category:	OVC III
Power consumption:	≤ 27VA, ≤ 12W (PQ5000CL-0/-1) ≤ 60VA (PQ5000CL-2/-3)

COMMUNICATION

ETHERNET

	via RJ45 jack
Standard protocols:	Modbus/TCP, NTP, http, https, IPv4, IPv6
Optional protocol:	IEC 61850
Physics:	Ethernet 100BaseTX
Mode:	10/100 Mbit/s, full/half duplex, autonegotiation

MODBUS/RTU

	via plug-in terminal (A, B, C/X), only PQ5000CL-0/-1
Protocol:	Modbus/RTU
Physics:	RS-485, max. 1200m (4000 ft)
Baud rate:	9'600, 19'200, 38'400, 57'600, 115'200 Baud
Number of participants:	≤ 32

INTERNAL CLOCK (RTC)

Uncertainty:	± 2 minutes/month (15 to 30°C)
Synchronization:	none, via Ethernet (NTP protocol) or GPS
Power reserve:	> 10 Years

ENVIRONMENTAL CONDITIONS, GENERAL INFORMATION

Operating temperature	-10 up to <u>15 up to 30</u> up to +55 °C
Storage temperature	-25 up to +70 °C
Temperature influence	0.5 x basic uncertainty per 10 K
Long-term drift	0.5 x basic uncertainty per year
Application group:	II (acc. EN 60 688)
Relative air humidity	<95 % without condensation
Operating altitude	≤2000 m above NN
Only to be used in buildings!	

MECHANICAL PROPERTIES

Flammability class	V-0 according UL94, self-extinguishing, not dripping, free of halogen
Weight	600 g (PQ5000CL-0/-1) 1.5 kg (PQ5000CL-2/-3)

SAFETY

Current inputs are galvanically isolated from each other.	
Protection class	II (protective insulation, voltage inputs via protective impedance)
Pollution degree	2
Protection	
• PQ5000CL-0/1:	IP40 (front), IP30 (housing), IP20 (terminals)
• PQ5000CL-2/-3:	IP66 (housing), IP43 (connections)
• Current Module 3P/3PN:	IP43
• Rogowski coils:	IP67



ORDER CODE PQ5000CL FIELD HOUSING

LINAX® PQ5000 Current Link Multifunctional Power Quality Analyzer

Design & Display		Nominal frequency	Current measurement in base unit	Power supply	Connection for GPS time synchronization	Function USB connection	IEC 61850 protocol	MQTT protocol	Current-Link RMS1/2 disturbance recorder	Extension 2 (Connectivity)	Article Number
In field housing, without display	In field housing, with TFT display	50 Hz	Without	Via measuring input L1-N, nominal voltage 100..230V	Without	None	Without IEC 61850 protocol	Without MQTT protocol	Without	Test certificate English	
•	-	•	•	•	•	•	-	•	•	•	
-	•	•	•	•	•	•	-	•	•	•	193009
-	•	•	•	•	•	•	-	•	•	•	193017

ACCESSORIES

ARTICLE NO.

Current module 3P, with 3-fold Rogowski converter Ø75mm, approx. 0,5 m connection cable Colors: L1 = brown, L2 = black, L3 = grey	187 593
Current module 3PN, with 4-fold Rogowski converter Ø75mm, approx. 0,5 m connection cable Colors: L1 = brown, L2 = black, L3 = grey, N = blue	187 105
Current module 3P, with 3-fold Rogowski converter Ø100mm, approx. 0,5 m connection cable Colors: L1 = brown, L2 = black, L3 = grey	189 137
Current module 3PN, with 4-fold Rogowski converter Ø100mm, approx. 0,5 m connection cable Colors: L1 = brown, L2 = black, L3 = grey, N = blue	189 129
SMA connection cable BM-RCM, length 0.5 m	187 634
SMA connection cable BM-RCM, length 1 m	188 585
SMA connection cable BM-RCM, length 1 m	190 777
SMA connection cable BM-RCM, length 5 m	187 642
SMA connection cable BM-RCM, length 10 m	187 650
... other lengths on request	



Current module **3P**, with 3-fold Rogowski converter



Current module **3PN**, with 4-fold Rogowski converter



SMA connection cable BM-RCM



DIMENSION DRAWING PQ5000CL FIELD HOUSING

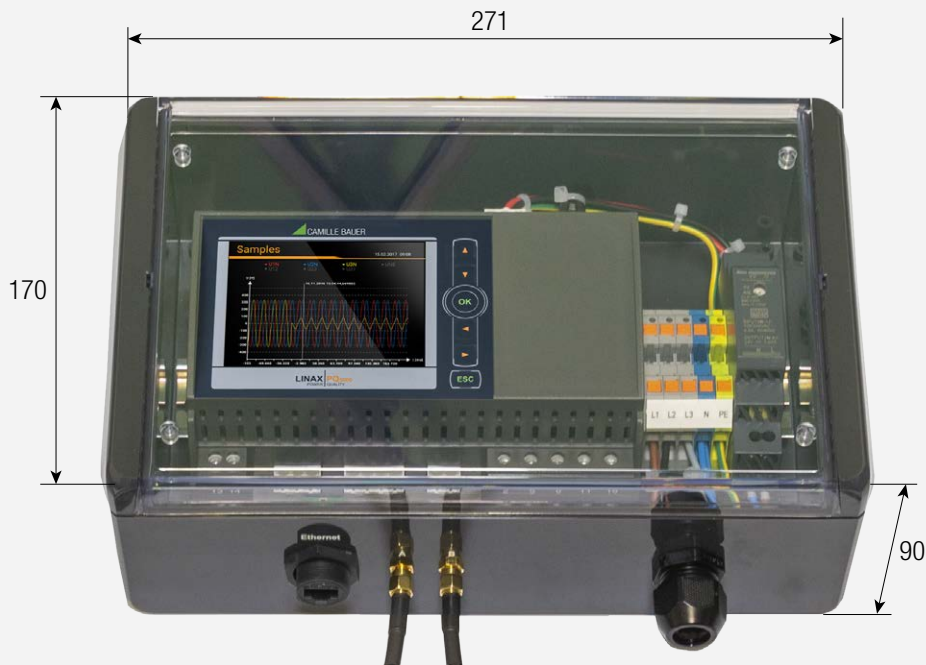

PQ5000CL in field housing with TFT display



TRANSPARENCY IN THE SMART GRID

Exemplary holistic approach of Camille Bauer Metrawatt AG

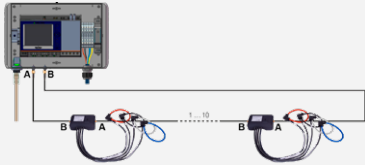

1. Real-time measurement with LINAX® PQ5000CL

- Load flow
- Power quality

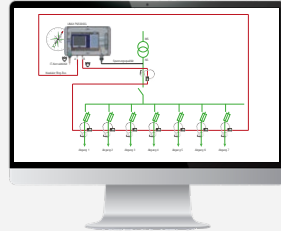

2. Grid cockpit

- Visualization of the measurement locations/ measurement points
- Remote control signals by means of limit values



3. Analyses

- Load flow
- Power quality

Comprehensive grid monitoring

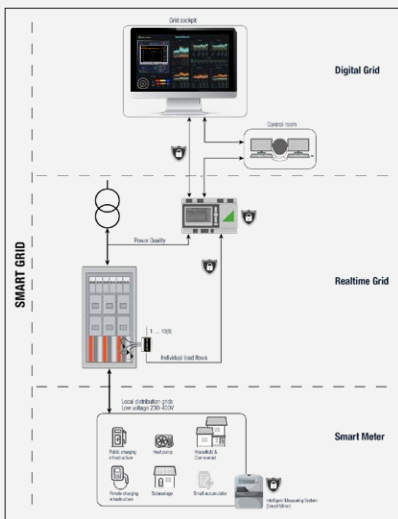

Aspects of Smart Grid Monitoring with SMARTCOLLECT SC²

1. Interactive single line overview

2. Flexible dashboards

3. Event and alert notifications, or output of control signals

4. Multi-device and brand data handling

5. WebGUI integration of the measuring devices

6. Energy Monitoring System (EMS)

7. Sophisticated zoom function

8. Interactive 2D/3D aerial view

9. Multi-data communication

10. Secure web-based system



TRANSPARENCY IN THE SMART GRID

Exemplary holistic approach of EVUtion AG

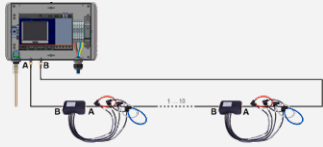

1. Real-time measurement with LINAX® PQ5000CL

- Load flow
- Power reserves
- PQ Reserves (U/I)



2. Analyze / Decide

- Reduce power peaks
- Optimize ripple control
- Ensure voltage/current quality



3. Act

- Load management (heat pumps, batteries, e-mobility, etc.)
- Production management / redispatch (PV, batteries, CHP, etc.)
- Grid expansion - only according to necessity

Implementation by means of IT high-performance platform

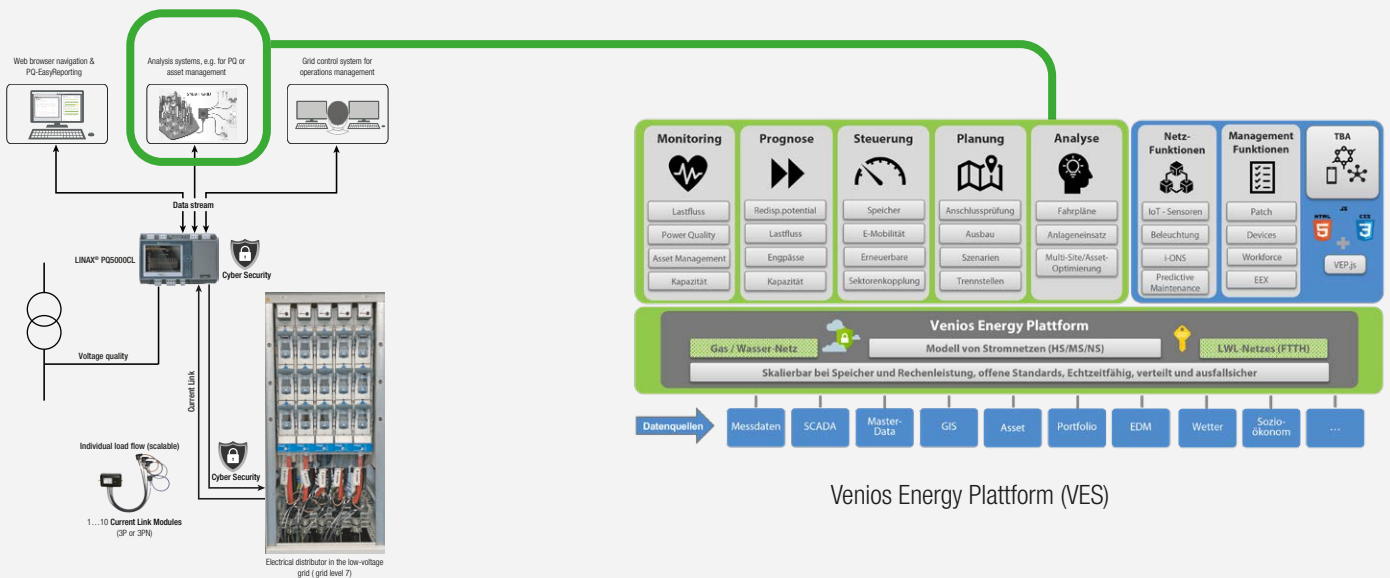

Venios Energy Plattform (VES)

Aspects of the Venios Energy Platform

1. Transparency

Link data from individual applications. Create computable networks and recognize sources of error in the upstream systems. Combine model data and measured values as desired. Visualize network structure and network state in real time.

2. Taxes

Optimized control of flexibilities. Controllable local network transformers for voltage adjustment. Control of charging stations via load forecasts. Counteracting grid bottlenecks by calling up flexibilities.

3. Forecast

Load forecasts for the next day. Network condition forecasts to detect bottlenecks at an early stage. Create scenarios for future network situations incl. simulation of switching operations. Precise forecasts based on measurement data and algorithms. Basis for planning.

4. Planning

Automate processes. Plant connection: simple handling, precise output. Detect network bottlenecks early and act intelligently. Asset manager: derive actions from current conditions.

5. Partner applications

The Venios ecosystem offers a multitude of use cases, whose enormous added value only arises from the intelligent networking of partner and customer applications with different functions.



TRANSPARENCY IN THE SMART GRID

Exemplary holistic approach of Swistec

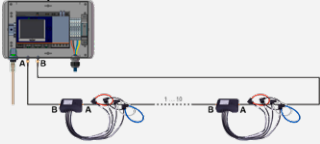

Device	Location	Phase	Current	Voltage	Power	Energy	Power Factor	Harmonics	Temperature
010001	Line 1	A	10.5	230	2400	100	0.95	5%	40
010002	Line 1	B	10.2	230	2340	95	0.95	5%	40
010003	Line 1	C	10.8	230	2480	105	0.95	5%	40
010004	Line 2	A	11.0	230	2530	110	0.95	5%	40
010005	Line 2	B	10.7	230	2460	105	0.95	5%	40
010006	Line 2	C	11.2	230	2570	115	0.95	5%	40



1. Real-time measurement with LINAX® PQ5000CL

- Load flow
- Power Quality

2. Manage

- Grouping of loads and generators
- Lifecycle management of the load control units

3. Taxes

- Measuring devices in transformer stations trigger events
- Ripple control system triggers fine granular control commands

Grid-serving control by means of fine-granular load control

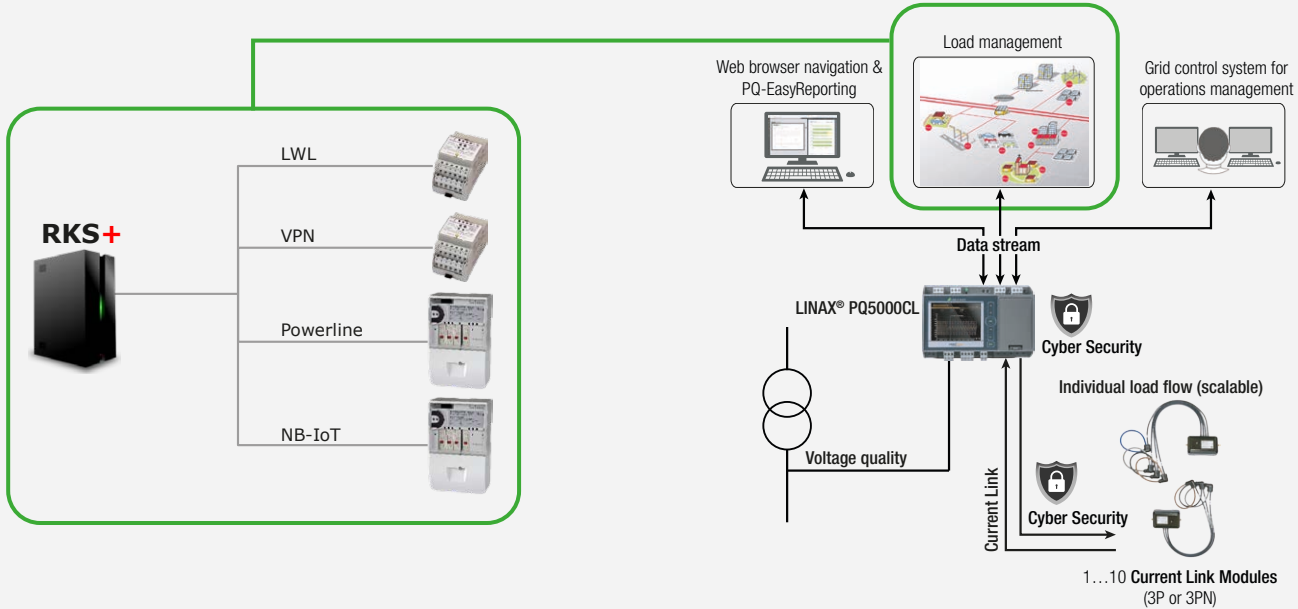

The accuracy and versatility of the Camille Bauer meters extend the RKS load management system into an intelligent, fine-granular network control system. In the event of critical network conditions, the measuring devices

in the transformer stations generate events that are sent to the RKS system, where they are converted into fine-granular load control commands. The RKS+ addresses the affected load control devices via secure

IP communication and thus ensures that the network state returns to normal by switching flexibilities.

Aspects of load control with IP ripple control

1. Open system architecture

With various interfaces such as IEC 60870-5-101/104, the RKS system is open for communication with control systems. In addition, .NET DLL and web server are available as further interfaces.

2. Modern communication

The measuring devices communicate with the ripple control center via MQTT, a proven and freely scalable IoT communication.

3. Steering groups

In a control group, the IP-based load control devices can be addressed via 4 address levels. In addition, each load control device has an individual address via which it can be controlled.

4. Lifecycle Management

Categorization and management of load controllers by operating status (not installed / in test mode / in operation).

5. Security

Depending on the load controller used, the switching and parameterization commands are encrypted via TLS1.2 or AES-GCM-256.

6. Audio frequency ripple control

With Swistra, the advantages of fine-granular control can also be realized for audio-frequency ripple control.



TRANSPARENCY IN THE SMART GRID

Exemplary holistic approach of Fichtner IT Consulting

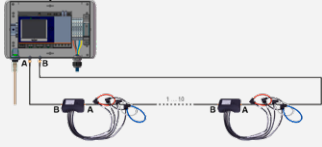

1. Real-time measurement with LINAX® PQ5000CL

Certified and safe power quality measurement and power analysis with up to 32 currents in the sub-distribution.



2. Digital grid image

Derive grid situation and topology from existing sources into a digital grid image.

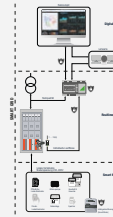

3. Comprehensive grid cockpit

Interactive visualization of the measured values at the measuring points and the resulting grid situation in the grid diagram.



3. Topological final result

Provision of analyses and forecasts of further developments in the grid for the specific departments.

The topological end result with analytics and prognostics

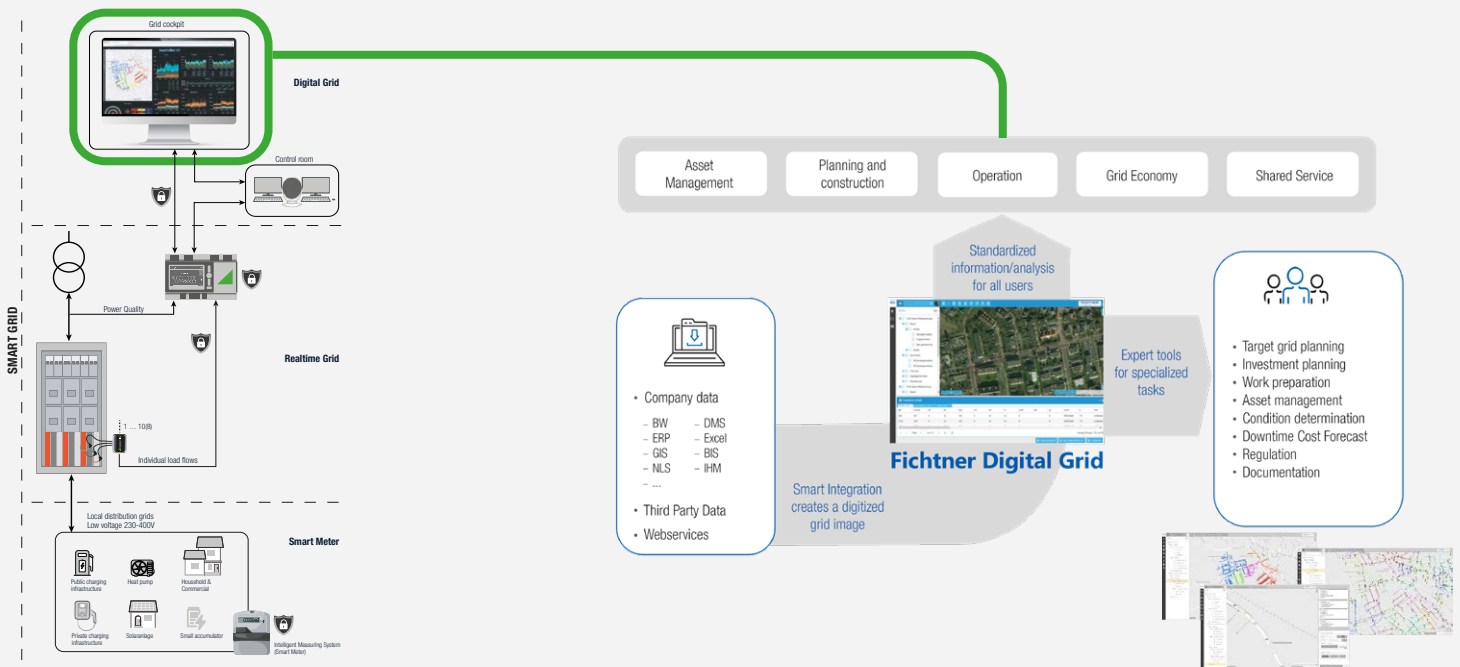

Aspects of the Fichtner Digital Grid

Asset & Aging Management

- Modules Smart Data Integration, Calculate: construction of topological grid model, grid calculations (coupling PowerFactory)
- Maintain module: maintenance (interface to IT system of fault management or directly via message from measurement)
- Analytics module: Impact analysis in the event of equipment failure (e.g., own analyses by the utility (in planning))
- Optnet module: Determination of condition of equipment (aging)
- Module Failure Monitor: Active messages and display in municipal portals in the event of failures & recommissioning

Flexibility Management

- LV grid traffic light next day: Input forecasts for next day (e.g. 24h), calculation of feed-in adjustments for next day.
- Real-time grid traffic light: Calculation of necessary load/feed-in corrections or shutdowns (based on real measured values)
- Real-time switching operations: Camille Bauer control channel for smart meter gateway or similar when the real-time grid light is red (this is currently only possible via a different, relatively cost-intensive device)
- Forecast for the LV grid based on the measured values and SMGW to avoid balancing energy
- Freely configurable interfaces, for example to ripple control and CLS channel (FNN control box)



MEASUREMENT COMPASS FOR MOBILE USE

Mobile device for evaluating load profiles and power quality in low voltage (grid level 7). Also very well suited as preliminary stage to a permanent smart grid application.

LINAX® PQ5000 Mobile CL-MultiPQ

- Portable PQI multichannel meter according to IEC 61000-4-30 Ed. 3 of class A
- Comprehensive PQ analysis for all voltages and currents
- Metrological certification IEC 61000-4-30 by METAS according to IEC 62586-2
- Integrated WebGUI as HMI, incl. comprehensive cyber security
- Hard case with IP65 with closed housing
- Power supply 100 up to 230V AC/DC via mains adapter 300V CAT IV
- Nominal frequency 42...50...58 Hz
- Safety requirement 600V CAT IV (measuring inputs current & voltage)
- 64GB SD memory
- Maximum of 36 current measurement inputs per device (9 x L1/L2/L3/N)
- 1 x voltage tap L1/L2/L3/N/PE by means of voltage measuring leads
- Fault recorder for current and voltage events: RMS $\frac{1}{2}$ values of all voltages and up to 36 currents as well as waveform recordings of the voltages
- Incident recording up to 3 minutes after the event
- Display and evaluation via WEB interface of the device
- Event list with trigger source, event type, event duration and characteristic event values
- Zoom options & data points for on-site analysis
- Comprehensive load profile recording
- Time synchronization via NTP server or GPS
- Data export via CSV files
- Current values are time synchronized to voltage (IEC 61000-4-30)
- UPS on capacitor basis (min. 30 seconds bridging)
- Data protocols: http, https, IPv4, IPv6, NTP, REST API
- Data communication via LAN or WLAN access point to various end devices
- Evaluation via PQIS® software possible

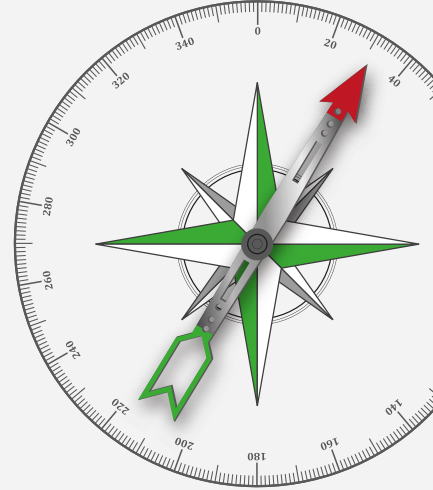

LINAX® PQ5000MOBCL-MultiPQ

Connectivity (LAN/WLAN):

- http, https, IPv4, IPv6, NTP
- REST API
- CSV
- PQ EASY-REPORTING
- PQIS®



Web navigation

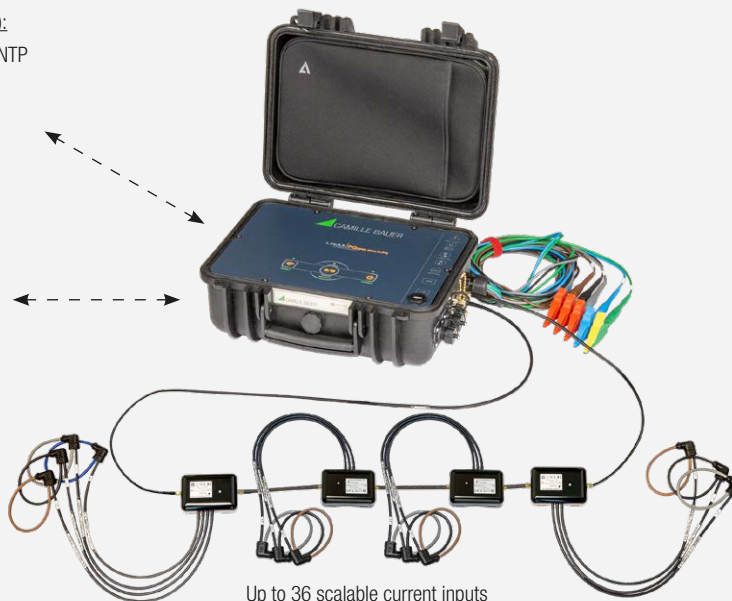

Up to 36 scalable current inputs



OUR PORTFOLIO

Measuring and Displaying



Grid management and equipment monitoring require precise and reliable information of different grid variables. For this purpose, we offer a wide range of high-quality instruments to acquire all variables of the electrical grid.



Position sensors

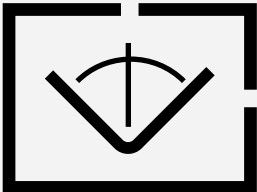

With our portfolio of POSITION SENSORICS we offer solutions for angle, position and inclination measurement. Here, the offer ranges from simple built-in devices to the robust devices for applications in harsh environments. The angle and inclination measuring systems serve as an important link between mechanics and control.



Power Quality



Modern power electronics and non-linear consumers increasingly impair the electrical grid which is the reason why alternating current has not shown the original sinusoidal characteristic already for a long time. This bears heavily on electrical devices and machines and extends to higher thermal losses, increased energy consumption through to the disturbance and downtime of plants. Our solutions ensure that problems are early recognised, even before they occur.



Monitoring and controlling



We offer the unique possibility of not only acquiring all variables of the electrical grid precisely and reliably, but also processing them directly via a PLC integrated into the device and controlling processes. This enables us to realise process controls directly at the measuring point. You thus save a separate PLC or you realise an autarkically working redundant solution.

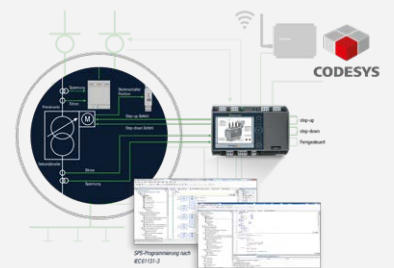

Software and Systems



We design modular customer-specific solutions and systems which can be extended at any time regardless of manufacturer.

Through our non-proprietary interfaces is also an integration in already existing applications and systems with components from different manufacturers no problem.





CAMILLE BAUER

GMC-INSTRUMENTS GROUP

Camille Bauer Metrawatt AG
Aargauerstrasse 7 ■ 5610 Wohlen ■ Switzerland
TEL +41 56 618 21 11

www.camillebauer.com ■ sales@camillebauer.com

Subject to change without notice ■ SW-1057-000-04-EN-07-24
1002870 000 01